

NETOMETER-II

refining the art of frequency maintenance



**Information Manual
Version 1.2**

© GW4GTE January 2011
www.s9plus.com

Contents

	Introduction	2
1	Circuit Description	3
	1.1 Input Amplifier.....	3
	1.2 Processing.....	4
	1.2.1 Control Lines	4
	1.3 Output.....	5
	1.3.1 LED Display	5
	1.3.2 Meter Display	5
2	Construction	6
	2.1 Choosing a Power Source.....	6
	2.2 Connectors	6
	2.3 PIC Chip Firmware	6
3	Testing and Setting Up	7
	3.1 Initial Testing	7
	3.2 Powering up	7
	3.3 Display Calibration	7
	3.4 Link Settings	7
	3.4.1 JP1 Display Orientation	7
	3.4.2 JP2 Meter Sensitivity	7
	3.5 PL1 Pin connections.....	8
	3.5.1 Channel Selection Switches	8
	3.5.2 Store Button	8
	3.6 Connecting to an RF Source	8
	3.6.1 Indirect Connect	8
	3.6.2 Direct Connect	8
	3.7 The Effects of Modulation	9
	3.8 Connections for single frequency operation	9
4	Operation	10
	4.1 Standby Mode	10
	4.2 Programming a Channel.....	10
	4.3 Meter Display Direction and Sensitivity.....	10
	4.4 LED Display	11
5	Specification	13
	Appendix 1 PCB Layout	14
	Appendix 2 Photo of completed PCB.....	15
	Appendix 3 Parts List	16
	Appendix 4 Circuit diagram	17

Introduction

The original Netometer article appeared in issue 6 of *Signal* (January 2008). Intended for use with VFO based transmitters, the Netometer concept is that of a frequency indicating device that displays frequency error rather than actual frequency. As well as keeping the LED readout of the original version, this revised design adds a moving coil meter to indicate frequency error; somewhat in the style of the old Band 2 FM radio centre-zero tuning meters.

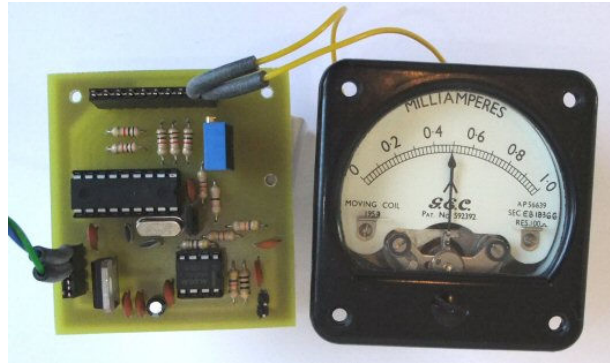

Figure 1. Completed unit with meter display
(current PCB differs slightly)

With Netometer II the author decided to amend the circuitry to allow the builder to adopt a more *vintage* display format (see figure 1 above). The original idea was to create a small battery-powered device as a piece of portable test gear, and an array of LEDs was the obvious choice for the readout. This second version adds circuitry to drive a standard left-hand-zero meter, but with an electronic offset to turn it into a centre-zero meter. The LED display circuitry of the MK I is retained and either or both displays can be used.

Section 1. Circuit Description

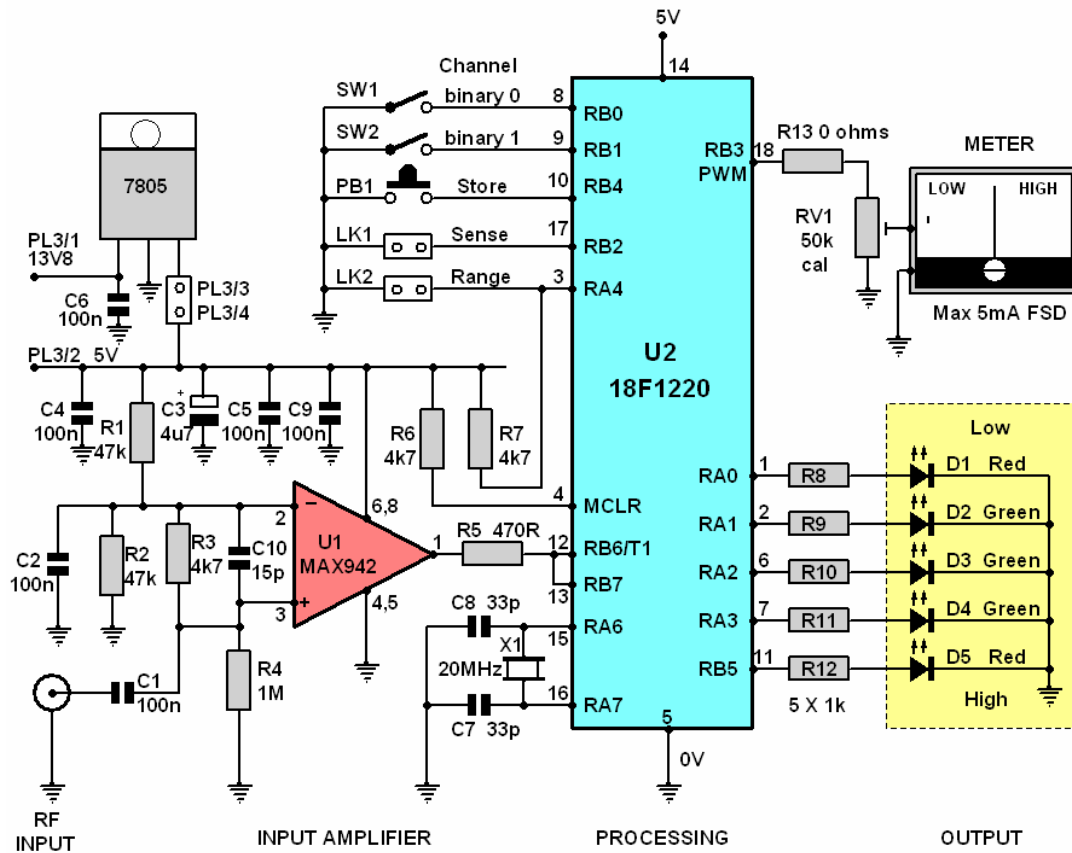

Figure 1.1 Circuit Diagram

The circuit, shown in figure 1.1 above can be broken into three parts, input, processing and output.

1.1 Input amplifier

U1 is a MAX942 high speed comparator in a convenient and compact 8-pin DIL package (actually the chip contains two comparators but the second one is unused here).

Any hint that the voltage on the positive input pin is greater than that on the negative input pin and the output will immediately go high to its maximum extent. Similarly a higher voltage on the negative input results in the output going fully low. In reality this takes a finite time, but the switching speed of the MAX942 is fast enough for a useful performance up to and beyond the design target of 10MHz. There is some hysteresis built into the comparator's input circuitry which helps by reducing the chance of self oscillation with small inputs. C13 also helps in this regard.

R1 and R2 set a centre-rail bias level for the comparator where it is more sensitive and the potential divider R3 and R4 ensure the negative (inverting) input is more positive, thus the no-signal output rests at zero Volts. The input impedance is defined almost entirely by R3. If a 50 Ohm input impedance is required, simply place a 50 Ohm resistor across the input socket.

A suitable RF input will create a square wave at U1 pin 1 as the signal raises the level on the positive pin. The output is fed to the PIC processor via R5.

The meter option allows easy integration into any equipment that contains an existing panel meter working against ground; all that is needed is a spare (break before make!) switch position to connect the meter. For single channel use there are no other controls required once the channel has been programmed.

1.2 Processing

The heart of the unit is the PIC processor- effectively a small, self contained computer with input/output (I/O) pins that can be programmed to do various tasks. Internally the PIC has a number of sub units such as timers and counters and a pulse width modulator, and these can be allocated to various I/O lines as needed. In this application one of the counters is used to count the frequency, and the pulse width modulator is used to drive the meter display.

The PIC's internal counter presents a bit of a problem as the optional pre-scaler is needed to provide the correct resolution without counter overflow, and the value of the pre-scaler cannot be directly read. There is a technique for deducing the value however.

Amplified and squared signals from U1 are fed to the PIC via R5. At the end of each 100ms gate period, U2 pin13 is changed from its normal high impedance state to a low impedance output, set at zero volts, swamping the input from U1, which is happy driving the 470 Ohm load (R5) it is now presented with. If pin 13 is now toggled between 0V and 5V, each successive toggle will be seen as a further count input at pin 12. U1 has no influence as it is effectively isolated by R5 from the low impedance level on pin 13. The PIC reads its main counter after every toggle, waiting for the value to increment (i.e. waiting for the pre-scaler to overflow). When it does, the number of toggles needed is subtracted from the pre-scaler modulus to derive the original pre-scaler value.

For example, say the pre-scaler is set to divide by 16, and a non-readable, currently unknown pre-scaler count of 7 is left at the end of the gate period. The input is toggled 9 times via pin 13 until the pre-scaler overflows, adding one to the main counter as a carry bit. The PIC then subtracts the toggle count from 16, producing the original pre-scaler count of 7. This is added to the main count to produce the final count value to 10Hz resolution (gate period is 100ms).

This technique is actually an official Microchip workaround, described in their application note AN592 [2]

1.2.1 Control Lines

Several PIC I/O lines are designated as inputs. Internal pull-up resistors are activated to save on external components. R7 is used because no internal pull-up resistor is available on that port. Two other PIC pins are used as binary channel selection inputs giving up to four channels. These pins have internal pull-up resistors activated to save on external components.

SW1 and SW2 control the channel selection. Any switching method can be employed – rotary switch, toggles etc.

JP1 and JP2 set the display direction and the sensitivity of the meter display. More about this later.

PB1 is a momentary push-button used to program a frequency into a channel.

1.3 Output

The error display is by means of LEDs or a moving coil meter (or both)

1.3.1 LED Display

There is a window of error values associated with each LED such that one or more LEDs are lit according to the amount and direction of frequency error. For instance when a frequency is more than 2.5 kHz low, LED1 is made to flash. The outermost LEDs are red to indicate larger errors. Green LEDs are used for the three inner LEDs. The LED components can be omitted altogether if the meter is used as the primary display.

1.3.2 Meter Display

The PIC has the ability to produce a pulse width modulated (PWM) output on one of its pins, and this signal is used to drive the meter. A pulse width of 50% gives a symmetrical square-wave at a given frequency (in this case arbitrarily chosen as 5 kHz). Measured against 0 Volts, a 50% duty cycle output represents 2.5 Volts, averaged over time.

When this signal is applied to a moving coil meter, the inertia of the mechanism prevents the needle following the peaks and troughs, and instead it settles on the average value. To calibrate, RV1 is adjusted with no signal (50% PWM) to give a centre-scale display. The meter will then read zero to full scale for 0% to 100% PWM. The PIC generates a PWM signal corresponding to the frequency error.

The PWM output has 8-bit resolution giving 256 steps – enough to produce a smooth meter movement on most meters.

An optional link on the PCB (JP1) reverses the meter reading and LED display for transmitters that have backwards tuning VFOs such as the AT5 on 160m. A second link (JP2) gives a choice of two meter sensitivities, +/- 600Hz or +/- 2.5 kHz. The LED display sensitivity is constant at +/- 2.5 kHz .

Any left-hand-zero meter with an FSD less than 5mA will be suitable.

Section 2. Construction

Referring to the PCB component layout in Figure 2.1 below, components can be applied in any order. However, soldering the IC sockets first makes it easier to identify component locations. Fit the ICs last, taking care with pin orientation.

A large size, printer friendly version of the PCB layout is included Appendix 1. A parts list is shown in Appendix 3 and a large circuit diagram in Appendix 4.

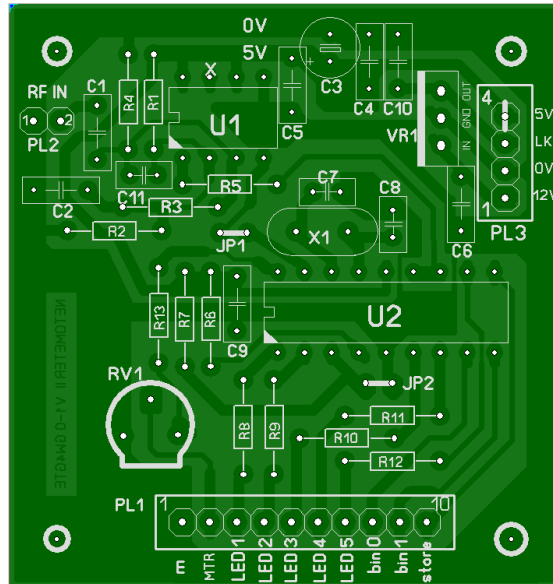

Figure 2.1. PCB Layout

2.1 Choosing a Power Source

If a 5 Volt supply is available, VR1 can be omitted. Power is then applied via PL3/4 and 0V. For supply voltages between 7V and 30V, VR1 is required. Apply power via PL3 /1, also linking PL3/3 and PL3/4 to connect VR1 into circuit.

2.2 Connectors

The low cost connectors supplied are shown in figure 2.2. Either the male or female end can be PCB mounted. A strip of Veroboard can be used to facilitate soldering of wires (figure 2.3)



Figure 2.2 Board Connectors

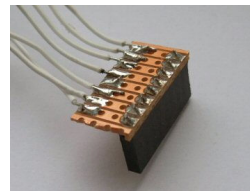

Figure 2.3 Using Veroboard

2.3 PIC Chip Firmware

If you have received a kit, the 18F1220 PIC chip will have been programmed with the latest firmware and functionally tested before shipping. If you decide to source your own components you will still need your PIC to be programmed. Just send your PIC chip together with an s.a.e. and your programmed and tested chip will be sent back to you by return. Alternatively, ready-programmed chips can be supplied at cost plus a small handling charge.

Section 3. Testing and Setting Up

3.1 Testing prior to initial power-up.

Visually check for solder bridges across PCB track – particularly in the places where the track passes between IC pins.

Using a test meter, check the resistance from the 5V line to earth. (positive meter lead to 5V line). With no ICs inserted and VR1 out of circuit, the reading should be around 90k, caused by R1 and R2. With both ICs inserted the reading is about 12k. With VR1 linked in the reading drops slightly to around 11k.

3.2 Powering up

Apply power. Initial current is around 20mA if the LEDs are connected. A one second lamp test occurs during which all the LEDs should be lit. With no RF input, the centre LED should then blink to indicate standby mode. Standby current is approx.13mA.

3.2 Display Calibration

LED display

There is no calibration procedure required for the LED display.

Meter Display

Any left-hand zero meter with a movement up to 5mA FSD is suitable. With no RF input applied, adjust VR1 to give a centre-scale reading.

3.4 Link Settings

These settings only have relevance when a signal is present. In standby mode the meter should always be in the centre position.

There are two PCB jumper links JP1 and JP2.

3.4.1 JP1: Display Orientation

With JP1 open the displays indicate increasing frequency from left to right.

When JP1 is closed the display sense is reversed. This is provided primarily for installations where the VFO tuning is reversed. i.e. more clockwise rotation of the tuning would reduce the frequency. One example is the Codar AT5 on 160m. (Operation is more intuitive when the display tracks the VFO).

3.4.2 JP2: Meter sensitivity

The meter sensitivity can be set to suit transmitter characteristics and user preference.

With JP2 open the meter movement at zero deflection and full scale represents a frequency error of +/- 620Hz.

Closing JP2 expands the scale to display errors of +/- 2.5kHz.

JP1 and JP2 also affect the LED display. See section 4.4 for more information,

3.5 PL1 Pin Connections

PL1 is a 10 pin connector with pin functions shown in table 5.1 below:

PL1 pin	Function	Notes
1	Zero volts (earth)	
2	Meter connection	To meter +ve (5mA max)
3	LED1	Left-most LED (red) LOW
4	LED2	Green LED
5	LED3	Centre LED (green)
6	LED4	Green LED
7	LED5	Right-most LED (red) HIGH
8	Bin 0	Binary channel selection
9	Bin 1	Binary channel selection
10	Store	Earth to set the channel

Table 3.1 PL1 connections

3.5.1 Channel Selection Switches

Up to four channels can be selected using PL1/8 and PL1/9, which are normally high unless connected to earth. Any suitable switching arrangement can be used including rotary switch, toggle switches or DIP switches. The settings need to be maintained to hold the channel. i.e. do not use push buttons.

3.5.2 Store Button

Connect a push button between PL1/10 and earth. This is used to program each channel – see 4.2 below.

3.6 Connecting to an RF source

Netometer II can work down to an RF input level of a few millivolts, but for best performance under modulation a carrier level of around 50mV to 250mV is recommended. The user will need to decide how to achieve this. There are two basic ways – direct connect and indirect connect

3.6.1 Indirect Connect

Depending on the field strength available, a length of wire say 1m long may suffice. Establish the minimum length of wire needed to get a lock then at least double it for best modulation performance. Some ATUs have an RF pick-up tap that may be suitable.

3.6.2 Direct Connect

The best method is to take a sample off the transmitter's main output via an attenuator or sniffer link. For example, if the coax run to the Netometer is short, make up an adapter cable, junction box, or otherwise tap in at a suitable point in the feeder run and connect a 10k 0.5W resistor from the coax inner to the Netometer II input. Place a 50 ohm resistor from the Netometer II input to earth to form a potential divider. You may need to reduce the 10k for carrier levels under 10W. Alternatively use a small toroid over the inner with a few turns as secondary, similar to an SWR meter pickup. If a dummy load can be used during testing instead of the antenna so much the better. See figure 3.1 below.

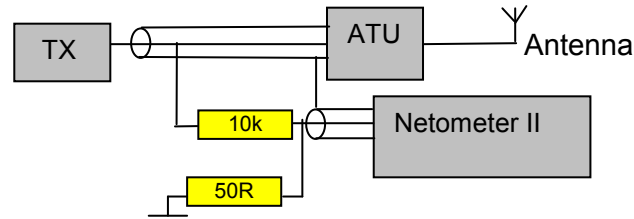

Figure 3.1. Direct connect suggestion

3.7 The Effects of Modulation.

When sampling a signal with high amplitude modulation peaks, occasional jumps in the display may be apparent. These should not be troublesome. If the effect is continuous during speech and an indirect pickup is used, try moving the pickup wire. Also try increasing the signal level into the unit. If the transmitter is producing asymmetrical modulation, or breaking up the carrier, the count, and thus the display will be affected. Carriers that change frequency when modulated will also affect the display.

3.8 Connections for single frequency operation

For dedicated use on a single frequency with meter display and no LEDs, the only connections needed are for power, RF input and meter.

The Store button is only needed for initial frequency programming and can be ignored if the target frequency does not change. The channel selection pins can be left unconnected. The LED wires can be left unconnected, or partially wired e.g. just connect the two end LEDs to indicate wide frequency errors and use the meter close-in.

Section 4. Operation

Summary

- Check the link settings for the display orientation and meter sensitivity.
- Power up the unit making sure the chosen channel is selected.
- Apply the RF signal to be checked.

4.1 Standby Mode

After switch on, with no input signal present, the unit is in standby mode. In this mode the centre green LED D3 will blink and the meter PWM output is set to 50%. RV1 adjusts the meter to give a centre reading.

4.2 Programming a channel

Select the required channel by means of the bin0 and bin1 channel lines. ***For single-channel use these connections can be left open circuit.*** With a steady unmodulated carrier on the desired frequency, press and hold the 'store' button. Almost immediately the meter will move to the centre position (assuming it has been calibrated – see 3.2 above) and the centre green LED will light. Release the button. All three green LEDs should now be lit.

The setting for that channel is now stored in the PIC's non volatile memory. No further programming is needed unless the stored frequency needs to be changed.

4.3 Meter Display Direction and Sensitivity

Closing Link 1 (JP1) reverses the display so that the meter deflection increases as the frequency reduces. Set the link so the display follows the transmitter VFO tuning. The LED indication is also reversed.

Link 2 (JP2) effects the display sensitivity. Close the link to select the lower sensitivity which reduces sensitivity by a factor of four.

There are 256 discrete steps between zero and full scale. This gives a smooth display on most meters although some jitter between samples may be noticed on large meters.

The Meter display is linear, unlike the LED display which is weighted to give a more sensitive display close to net (see below).

Meter range

Low sensitivity (JP2 closed) : zero to full scale is +/- 2.5kHz of centre zero frequency
High sensitivity (JP2 open) : zero to full scale is +/- 620Hz of centre zero frequency

Thus the meter legends can be altered to indicate actual frequency error. A meter with an FSD of 50uA, 500uA or 5mA is easy to interpret when the low sensitivity 0-5kHz range is selected (JP2 closed).

4.4 LED Display

The cut-over points between different LED displays have been chosen to give a greater sensitivity towards net.

Link 2 (JP2) effects the overall display sensitivity. Close the link to select the lower sensitivity which reduces sensitivity by a factor of four.

Closing Link 1 (JP1) reverses the display. Set according to VFO sense.

Table 4.1 and 4.2 below show the LED display for different frequency errors. Note these frequencies are approximate as the counter resolution is 10Hz.





LED Display	Signal Frequency Error
	>250Hz below reference frequency. Flashing LED indicates error > 2500Hz. Fast flashing LED indicates error > 5kHz
	>120Hz below reference frequency
	>60Hz below reference frequency
	>30Hz below reference frequency
	On Frequency +/- 30Hz
	>30Hz above reference frequency
	>60Hz above reference frequency
	> 120Hz above reference frequency
	> 250Hz above reference frequency. Flashing LED indicates error > 2500Hz. Fast flashing LED indicates error > 5kHz

Table 4.1 LED Display - high sensitivity (JP2 open)



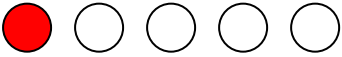
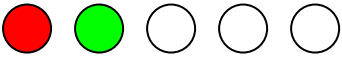
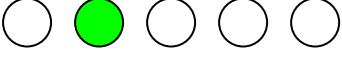

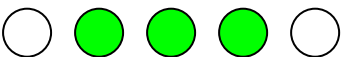
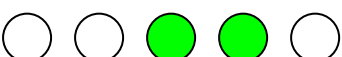
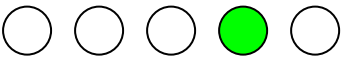

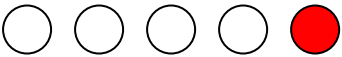
LED Display	Signal Frequency Error
	>1000Hz below reference frequency. Flashing LED indicates error > 2500Hz. Fast flashing LED indicates error > 5kHz
	>520Hz below reference frequency
	>220Hz below reference frequency
	>120Hz below reference frequency
	On Frequency +/- 120Hz
	>120Hz above reference frequency
	>220Hz above reference frequency
	> 520Hz above reference frequency
	> 1000Hz above reference frequency. Flashing LED indicates error > 2500Hz. Fast flashing LED indicates error > 5kHz

Table 4.2 LED Display - low sensitivity (JP2 closed)

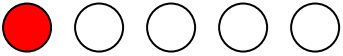
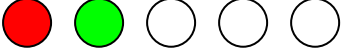
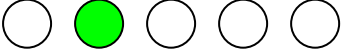
Section 5. Specification

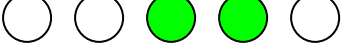
Frequency Coverage <10KHz to >10MHz
Frequency Stability: +/- 20ppm/degC
Gate Time: 100ms
Resolution: 10Hz
Sample Rate: > 8 samples/sec
Input Impedance:Nominally 4700 ohms
Input Sensitivity: Better than 20mV RMS
Maximum Input: Greater than 1V RMS
Amplitude modulation immunity:>50% mod. (1kHz tone) at 70mV RMS
Channels:4 reference frequencies can be stored in eeprom
Voltage Requirements: 5V or 7V to 30V via regulator
Current Drain in Standby Mode: <15mA
Current Drain in Operating mode: <25mA at 5V depending on LED status

Appendix 1. PCB layout

Print out this page to assist with assembly.

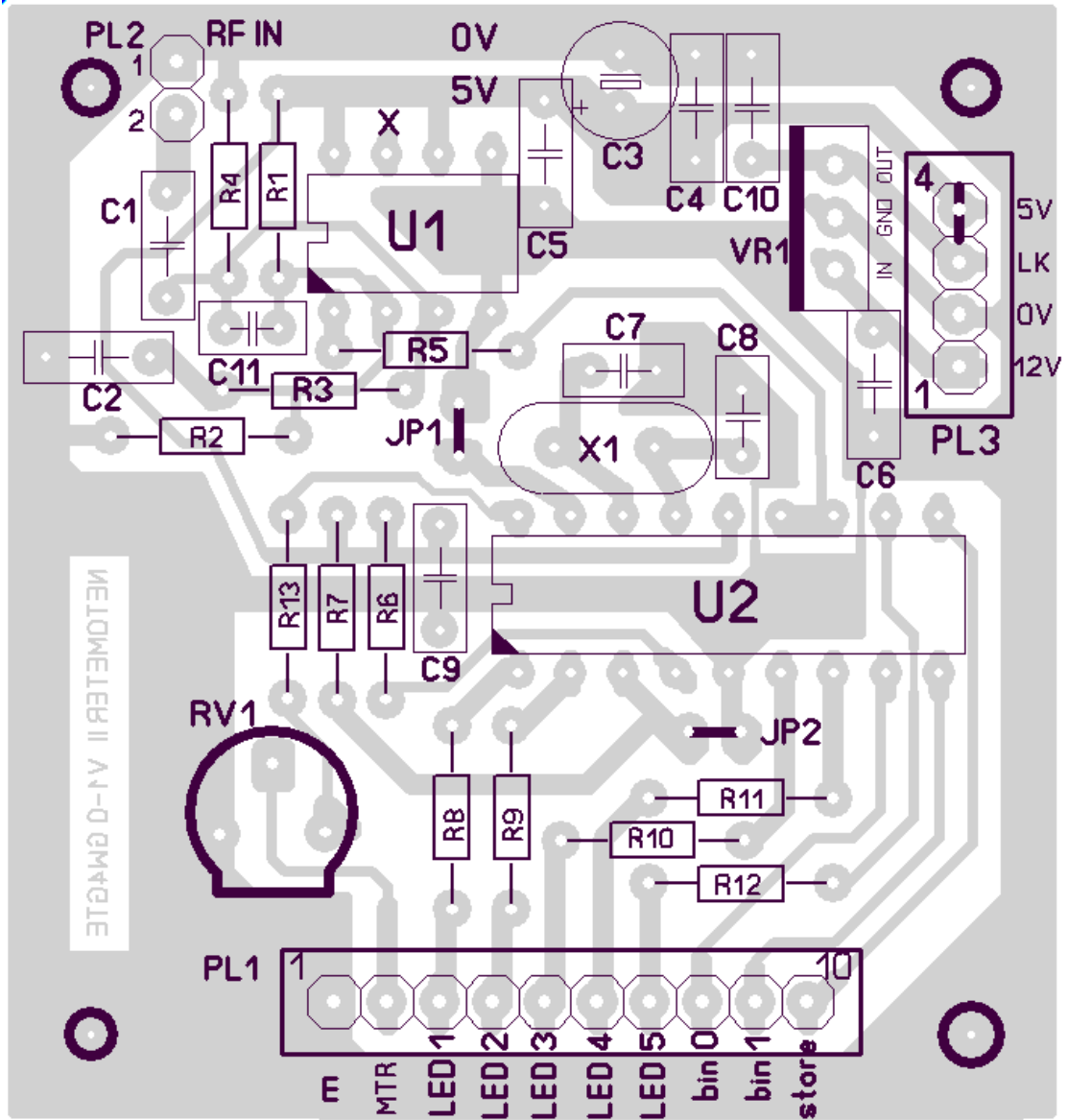

Appendix 2. Photo of assembled PCB

Refer to this page to assist with assembly.

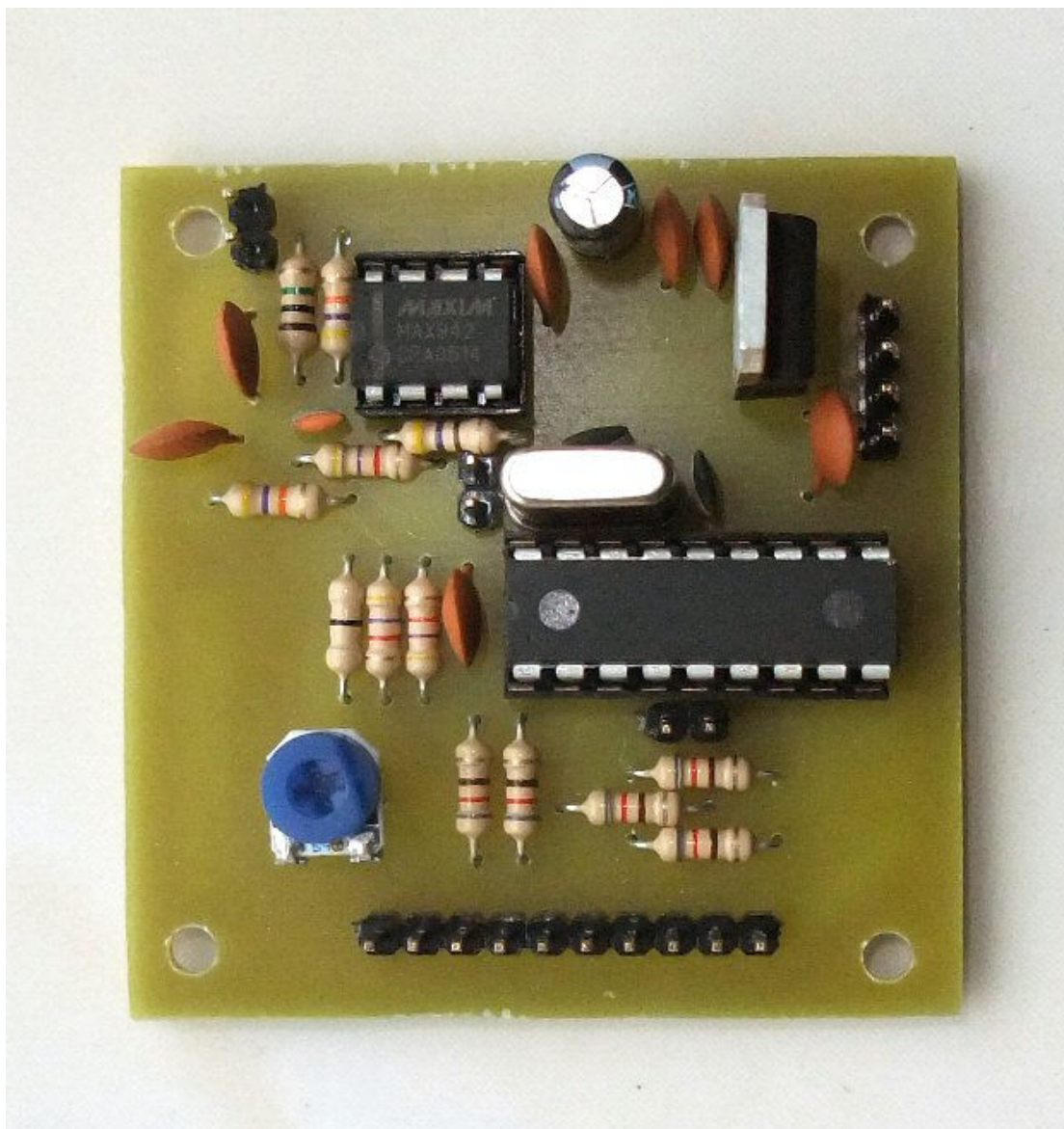

Appendix 3. Parts List

Print out this page to assist with assembly.

R1	47k 1/4w 5%
R2	47k 1/4w 5%
R3	4k7 1/4w 5%
R4	1M 1/4w 5%
R5	470R 1/4w 5%
R6	4k7 1/4w 5%
R7	4k7 1/4w 5%
R8	1k 1/4w 5%
R9	1k 1/4w 5%
R10	1k 1/4w 5%
R11	1k 1/4w 5%
R12	1k 1/4w 5%
R13	zero ohm link or sot for scaling
RV1	50k linear single turn preset
C1	100n ceramic
C2	100n ceramic
C3	4u7 electrolytic
C4	100n ceramic
C5	100n ceramic
C6	100n ceramic
C7	33p ceramic
C8	33p ceramic
C9	100n ceramic
C10	100n ceramic
C11	15p ceramic
VR1	7805 5V regulator
D1	LED red
D2	LED green
D3	LED green
D4	LED green
D5	LED red
U1	MAX942 op amp
U2	PIC 18F1220
X1	20MHz xtal 20ppm recc. 50ppm ok
PL1	10 way header strip (supplied with female conn.)
PL2	2 way header strip (supplied with female conn.)
PL3	4 way header strip (supplied with female conn.)
JP1	2 way header strip (supplied with shorting link)
JP2	2 way header strip (supplied with shorting link)
IC Socket	8 pin DIL for U1
IC socket	18 pin DIL for U2
PB1	Push button
SW1	Channel selection (not supplied)
SW2	Channel selection (not supplied)
Meter	5mA FSD max. (not supplied)

Appendix 4. Circuit Diagram

Print out this page to assist with assembly.

