

# Multi-Rock Information Manual



**Version 1.1.2**

**© GW4GTE 2010**

**[www.s9plus.com](http://www.s9plus.com)**

# MULTI-ROCK

A dual-band signal source for 160m/80m

This manual is the *complete reference document* for Multi-Rock, containing all aspects of construction and operation.

Multi-Rock was first described in the VMARS Signal magazine for October 2009. Information contained herein supersedes that article...

Please check you are reading the latest version of this document by checking [www.s9plus.com](http://www.s9plus.com) for any updates.

This manual is version 1.1.2, for hardware version 1.1.

**Please read this document fully before commencing construction**

**There are bound to be errors – please let me know when you find them!**

# Contents

<b>1</b>	<b>Hardware Description .....</b>	<b>5</b>
	1.1 Overview	
	1.2 Principle of Operation	
	1.3 Circuit Description	
<b>2</b>	<b>Software Description.....</b>	<b>9</b>
<b>3</b>	<b>Construction .....</b>	<b>10</b>
	3.1 PCB	
	3.2 Assembling the board	
	3.3 Order of Assembly	
<b>4</b>	<b>Testing .....</b>	<b>13</b>
	4.1 Test1. CPU functionality	
	4.2 Test2. Oscillator	
	4.3 Test3. DAC	
	4.4 Test4. Divider	
	4.5 Test5. Band Switching	
	4.6 Test6. Frequency Coverage	
<b>5</b>	<b>Interfacing .....</b>	<b>16</b>
	5.1 PCB Connectors	
	5.2 Switch Options	
	5.2.1 Tuning Switch Options	
	5.2.2 Channel Switch Options	
	5.2.3 Switch Layout Examples	
	5.3 Single Band Operation	
	5.4 Dual Band Operation	
	5.5 Extended Single Band Operation	
	5.6 The LOCK line	
	5.7 The LEDs	
	5.8 Interfacing to valve equipment	
<b>6</b>	<b>Operation .....</b>	<b>20</b>
	6.1 Power-up	
	6.2 Selecting a Channel	
	6.3 Programming a Channel	
	6.4 Adjusting a Channel	
	6.5 LED Interpretation	
	6.6 Auto-Setup	

<b>7</b>	<b>Error Mode .....</b>	<b>22</b>
	7.1 Error Mode 1 : No valid frequency present	
	7.2 Error Mode 2 : Frequency present but uncontrollable	
	7.3 Exiting Error Mode	
<b>8</b>	<b>Test Mode .....</b>	<b>24</b>
	8.1 Entering Test Mode	
	8.2 Test Mode Checks	
	8.3 Exiting Test Mode	
<b>9</b>	<b>FAT 5 Project .....</b>	<b>25</b>
	9.1 FAT5 RF Section	
	9.2 FAT5 Modulator	
	9.3 FAT5 Power Supply	
<b>10</b>	<b>Parts List .....</b>	<b>26</b>
	10.1 Component sourcing	
	10.2 PIC Chip	
	10.3 Components List Grouped by Reference	
	10.4 Resistors and Capacitors Grouped by Value	
<b>11</b>	<b>Specification .....</b>	<b>29</b>
	<b>Appendix 1 : PCB Layout .....</b>	<b>30</b>
	<b>Appendix 2 : LC Oscillator Option .....</b>	<b>31</b>
	A2.1 Determining C11 Value	
	A2.2 Using Multi-Rock on other frequencies	

# Introduction

Multi-Rock is essentially no more than a stabilised VCO. However, the stabilisation method used is also able to quickly establish then maintain frequencies recalled from a microprocessor memory. In other words a channelized VCO, or indeed a replacement for multiple crystals hence “Multi-Rock”.

There is nothing claimed as original in the design, however the author is not aware of previously published examples of VCO stabilisation and channel control being combined in this fashion.

Multi-Rock was designed as part of the FAT5 transmitter project [see *Section 9*] to provide a stable, channelised signal source on 80m and 160m. It can of course be used as a stand-alone unit for any purpose where a stable frequency source is required.

As part of the FAT5 project, the operational requirement is to produce a PCB based design to provide two carrier frequency TTL outputs in anti-phase. These signals are used as the push-pull drive for two FET driver ICs, which in turn drive the PA FETS. Inputs are provided for PTT, band switching, channel switching and tuning.

The Multi-Rock PCB is 3.5" x 2" in size and the circuit is powered from 5V, or a higher voltage via the optional on-board 7805 regulator. Kit assembly time is around one hour.

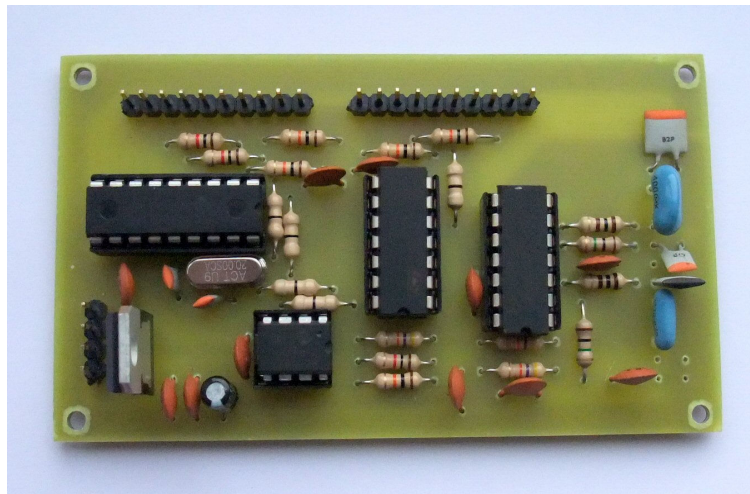

**Assembled Multi-Rock kit.**

***This is a fully supported project.***

*Please contact the author at [gw4gte@s9plus.com](mailto:gw4gte@s9plus.com) with any questions or problems before, during or after construction.*

# 1. Hardware Description

## 1.1 Overview

Multi-Rock is based around a simple varicap tuned voltage controlled oscillator (VCO), the basic frequency of which is determined by a ceramic resonator. This is a low cost device that can be pulled much further than a quartz crystal. Ceramic resonator frequencies are available that (when divided by 2) conveniently cover the UK 80m AM segment. 160m coverage is more limited when using a ceramic resonator due to frequency scaling, and the reduced effect of the varicap diode at lower frequencies, although LC components can be substituted (see Appendix 2). The oscillator runs at twice the required carrier frequency ( $2F_c$ ) in order to derive two anti-phase drive signals  $F_c$  and  $\underline{F}_c$ . Running at  $2F_c$  also allows the oscillator to operate continuously without creating on channel interference.

## 1.2 Principle of operation

### Control Loop

Consider a VCO. A potentiometer may be used to vary the voltage applied to a varicap diode, altering its capacitance and thus controlling the VCO frequency. Multi-Rock replaces the potentiometer with a microprocessor controlled digital to analogue converter (DAC) to generate the voltage instead.

The PIC contains a frequency counter, allowing a VCO sample to be compared to a stored target value. Any error is translated by the PIC into control signals to the DAC to generate a correction voltage which brings the VCO onto channel. The software continuously samples the VCO, automatically making adjustments as needed to keep the frequency constant and thus forming a control loop.

### Sampling and accuracy

The VCO is sampled with a gate period of 250ms, giving a resolution of 4Hz. As the VCO is running at twice the carrier frequency, the final resolution is 2Hz. The circuit is capable of holding the carrier frequency output to within 5Hz or less assuming the reference oscillator (i.e. the microprocessor clock) does not alter.

Thus rather than being *phase-locked* by the reference frequency, the carrier is *disciplined* by the reference frequency. Many methods exist for stabilising the signal further, but as the requirement here is for a signal source for an AM transmitter, it is considered that 5Hz or better is at least an order of magnitude greater than the accuracy required.

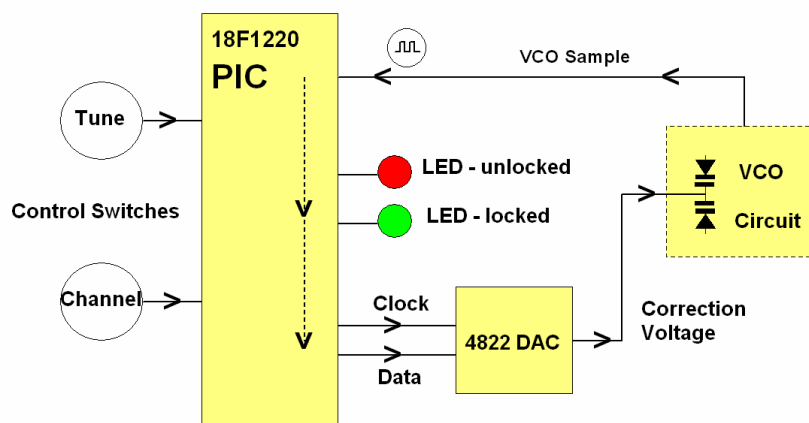

Fig. 1.1 Multi-Rock block diagram

### 1.3 Circuit description

The circuit diagram is shown in figure 1.2. The control loop of figure 1.1 is formed by the PIC U1, the DAC U2 and oscillator U3c or U3d, depending on the band in use.

#### PIC

The heart of the circuit is the PIC microprocessor. This versatile chip has many internal functions which can be allocated to I/O pins as required. There are no less than three internal counters available, but just one is used here to count the oscillator frequency. Most of the other pins are used to sense switch positions, drive LEDs, or send data to the DAC.

The 20MHz crystal X1 is the clock crystal that drives the PIC. It is also effectively the frequency reference for the PIC counter as the gate period is software defined and the speed of the software is locked to the X1 frequency. The kit uses a 20ppm part which provides more than adequate stability in normal use.

The PIC software runs in a continuous loop completing all frequency counting, DAC adjustments, LED driving and switch sensing once every 300ms or so. Software is described in more detail in Section 2.

Many I/O pins can have internal pull-up resistors allocated and wherever possible this has been taken advantage of to reduce component count. R1 and R2 are external pull-up resistors.

#### Oscillator

Logic gates can be biased into linear mode by applying heavy negative feedback between the output and an inverting input. R9 and R13 perform this function, and the associated circuitry around U3c and U3d produces a pair of oscillators, one for each band. Employing two oscillators was the easiest way of band switching especially as spare logic gates would otherwise remain unused.

Despite being biased for linear operation, logic gates can still be controlled by other logic inputs, offering a convenient way of gating the oscillators for band switching. U3a inverts the band select output from the PIC so that only one oscillator is enabled. U3b acts as a buffer, accepting inputs from either oscillator.

X2 (7.37MHz) and X3 (4.00MHz) are inexpensive ceramic resonators. The varicap diodes add capacitance that pulls the crystals down to frequencies within 80m and 160m. Coverage with the parts supplied is typically 3600kHz to 3640kHz on 80m, and 1965kHz to 1980kHz on 160m. For serious 160m operation an alternative is to replace the ceramic resonator with an LC circuit. This is covered in Appendix 2.

#### Digital to Analogue converter (DAC)

U2 is a dual 12-bit DAC. Twelve bits gives 4096 discrete levels, equating to about 1mV resolution. Both halves are used and the outputs combined via R5, R6, and R7. The 10:1 ratio between R6 and R5 gives a resolution of around 100uV at R11 with DAC A acting as coarse tuning and DAC B as fine tuning. Fine tune control (set by R6) is approximately +/- 5kHz on 80m with the component values shown.

## Signal Divider

U4 is a dual D-type flip-flop, and both halves are driven from the buffered oscillator output at U3/b. U4 is used to divide the oscillator output by two, producing two anti-phase outputs with an even mark-space ratio.

U4 is outside the control loop because stabilising at twice the desired frequency halves the final error. A pin on the PCB (2Fc) also allows the actual oscillator frequency to be used if required.

The RFA and RFB outputs are enabled respectively by TXA and TXB, active high. The PIC produces a 'lock' output when the control loop is established, and this can be used as the source voltage 'logic 1' for TXA and TXB to prevent transmission if the lock fails.

Having two sets of outputs, each with a dedicated PTT line offers flexibility in the final design. For instance, separate RF sections could be built, maybe QRP for 160m and QRO for 80m. For single band use, or dual band single path use, the second half of the flip-flop could be used as a QRP 'net' output, and keyed separately.

In the FAT5 project the U4 TTL outputs are used to directly drive two FET driver chips which in turn directly drive the PA FETs; and that's pretty much the FAT5 RF section done!

## Channel Selection

There are eight memory channels, four for each band. This is achieved by three control lines, two lines acting as a binary '0' and binary '1' channel number, and the third as a band switch. Toggle switches or a two-pole rotary switch could be used here (switches not supplied in kit). Section 5.2 covers switching options.

The PIC's memory stores not only the target count per channel, but also the last known DAC A value that produced that count. Memory recall is thus quite rapid because the DAC is pre-set with values very close to those required, avoiding a lengthy correction process within the control loop. Fine tuning from that point is a quick process.

Manual tuning of the VCO is also carried out with three control lines, two lines acting as 'up' and 'down' and the third as a coarse/fine selection. Coarse and fine would be used to initially set up each channel, after which only the fine tune would be used, if at all. Thus these lines could be brought out to switches on the rear panel or even mounted within the enclosure.

## LED indicators

Two LEDs provide a visual indication of status. When the unit is locked the green LED will flash once per count and the red LED stays unlit. When the red LED is lit continuously the oscillator is unlocked. Further details about the LED signals can be found in Section 6.5.

A single common-cathode tri-state LED could be used instead of two LEDs. ■



## 2. Software Description

A significant part of the functionality is performed by software that runs in the PIC processor. The software runs in a continuous loop, each cycle taking around 300ms. On each cycle the control inputs are outputs are serviced, the oscillator frequency is counted, and the DAC is adjusted to tune the oscillator.

### Control inputs

There are control inputs for band, channel and tuning (coarse/fine, up/down). Leaving all inputs open circuit will result in channel 0 on 80m being selected by default. There are various options for connecting the switches, and this is covered in Section 5.2.

### Control outputs

PIC pin 7 (RA3) provides a 'lock' signal, and goes high when the frequency is locked onto channel. This level can be used to enable the divider U4 so that only locked signals are output.

### PIC internal counter

The PIC contains three configurable internal counters, one being used here to count the oscillator. Reading high frequencies requires a pre-scaler to be enabled to avoid count overflow. Unfortunately the value in the pre-scaler cannot be read directly, so the value has to be deduced. There is a well publicised technique for this which most if not all PIC-based frequency counters use (Microchip App. Note AN592). However this technique is not ideal here, as without adding extra isolating circuitry, the brute-force method suggested is inclined to modulate the carrier.

Careful consideration about the range of frequencies covered in this design led the author to realise that a simpler method would suffice. All that is required is a count value unique to the target frequency, not a count of the actual frequency itself. With a suitable gate time the pre-scaler can be disabled and the main counter allowed to over-run. It doesn't matter how many times the main counter wraps round as long as it doesn't repeat over the range of frequencies required.

In this design the PIC async T1 16 bit counter is enabled for 250ms. Thus every count represents 4Hz, and the full range of counts without duplication covers  $65536 \times 4 = 262.144\text{kHz}$ . As the pull-range of the oscillators is less than 100kHz, unique values can be safely obtained. The potential control-loop problem at the count range maximum and minimum where a count of say 65533 could go a few counts high and wrap round through zero is (hopefully!) taken care of in software.

### DAC control

The MCP4822 dual 12-bit DAC is controlled from the PIC via three lines. Each time the DAC is updated, the EN line is lowered, and a serial data string is clocked into the SDI pin. Each bit of data is 'clocked' by toggling the SCK pin. Raising the EN line loads the new value into the DAC. Each DAC can be addressed separately. For more information please refer to the Microchip MCP4822 datasheet. ■

## 3. Construction

Multi-Rock can be built using any preferred layout technique although care should be taken with earthing and decoupling. PCB construction is recommended, and the artwork is available on request. It is anticipated however that most builders will take advantage of the complete kit that is available from the author.

### What's included in the kit:

The kit includes the PCB and all PCB mounted components including a programmed PIC, the 7805 regulator, the connector blocks and the associated connectors. A red and green LED are also provided (these are not mounted on the PCB).

### What's not:

Switches/buttons (the type and quantity depends on user preference and kit use), hook-up wire, solder, fixing screws, case, and power supply other than the on-board 5V regulator.

**Before starting, print out this section along with the next section, Testing. Also print out figure 1.2 above, the parts list at 10.3, and the board layout in appendix 1.**

### 3.1 PCB

Figure 1 below shows the bare Multi-Rock PCB. It is a tinned, single sided fibre glass board of dimensions 3.5" x 2". There are four mounting holes, one at each corner. The board is small and light so it is not necessary to use all mounting points.

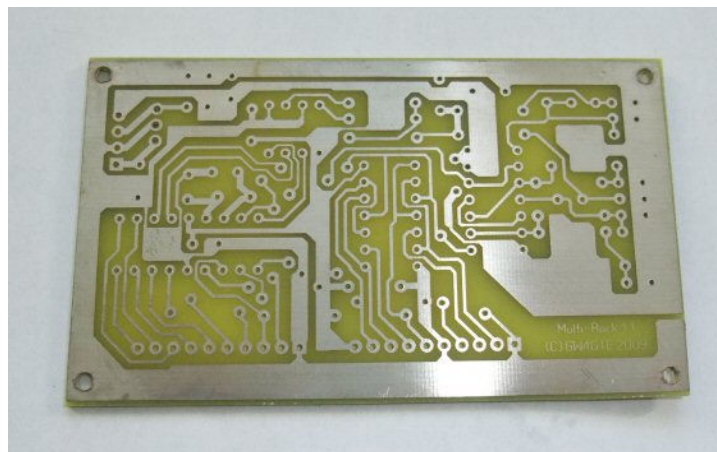

**Figure 3.1 Bare PCB**

Connections to the board are made via three connector blocks – two for signal and control and a third for power. The circuit requires 5 Volts, but an on-board regulator allows higher voltages to be used if preferred.

The kit includes basic pin connector blocks for low cost, although other 2.54mm spaced connectors such as higher quality Molex types (not supplied) may be substituted if desired. Wires could of course be soldered directly to the PCB.

### 3.2 Assembling the board

The PCB is supplied with the SMD parts VC1/VC2 and C15 pre-soldered. All other components are through-hole parts.

Figure 3.2 below shows the PCB artwork detailing component locations. The view is from the component side. (Note: To reduce cost the PCB currently supplied does not have a screen print layer). A larger, *printer ink friendly* version of this image is included in Appendix 1 and a copy should be printed out as component placement guide prior to starting construction.

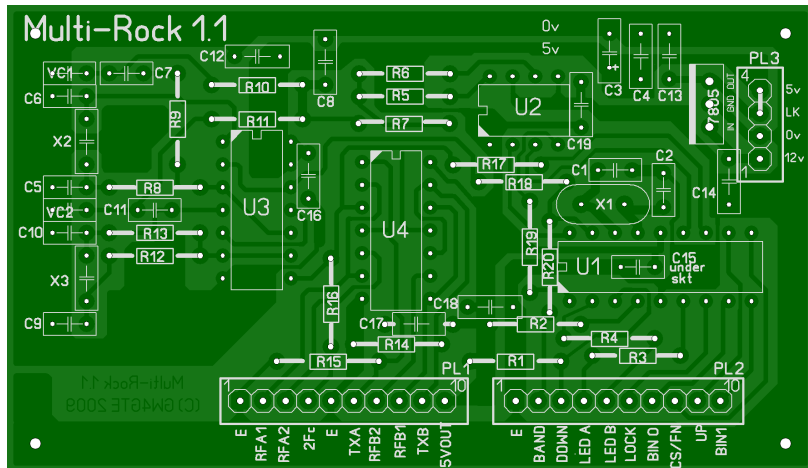

Figure 3.2 Component locations viewed from component side

### 3.3 Order of assembly

Construction is straightforward and there is no specific order of assembly. However, installing the IC sockets first to act as landmarks is recommended, followed by the lowest profile components first (resistors).

**IC sockets installed:**  (tick when completed)

Install with the resistors. They all mount horizontally. Try and keep the colour bands oriented the same way. Take care with similar coloured resistors e.g. 1k and 10k. Use an ohmmeter if not sure. R16 – R20 are zero ohm links (marked with a single black band).

**Resistors installed:**

[Read Appendix 2 first if other oscillator options are being considered].

Next fit the capacitors and ceramic resonators. If the resonators have a middle pin, snip it off. It has been found so far that C6 is not needed with the resonators supplied. Builders may wish to temporarily attach C5/C9/C10 to the track side of the PCB for easy removal until frequency checks are made (Section 4.6). C3 is an electrolytic – observe correct polarity.

NB: C13 and C14 are not required if the 7805 regulator is omitted.

**Capacitors and resonators installed:**

Now add the connector strips. Both the plugs and sockets can be PCB mounted – decide which is preferred, or mix the orientation of the 10-way connectors to avoid cable errors. A strip of veroboard can be used as a line of solder pads for the cable mounted connector.

**Connector strips installed:**

Fit the clock crystal X1, making sure the metal body of X1 does not touch any adjacent component leads, particularly R18.

Mount the 7805 regulator if required, with the heatsink tab facing away from PL3. (Note PL1/3 and PL1/4 need to be linked when using the on-board regulator).

<p><b>Use of the 7805 is recommended even if 5V is available. That way there is far less chance of an overvoltage being applied in error.</b></p>
---

**Crystal and regulator (if required) installed:**

**Do not install any ICs at this point**

**This completes the assembly of the PCB.  
Now proceed to Section 4. Testing**

## 4. Testing

*[This section assumes that the circuit has been constructed as described in Section 3 above.]*

Firstly, carry out a visual check of all soldered joints for bridges, particularly where the track passes between two pads. Before inserting any ICs, bend the leads parallel before attempting to plug the chip into the socket, otherwise there is a risk of bent pins. Also, double check the IC orientation.

Connect the two LEDs to PL2. The cathodes of the LEDs (the shorter leads) are connected to 0V. No other control connections are required at this stage.

Make sure the PCB is resting on a non-conducting surface. Check underneath in case any cut off component wires are lurking unseen.

You will now be applying power to the circuit. Make sure the correct pins of power connector PL3 are used depending on the chosen supply voltage.

### 4.1 Test 1 - CPU functionality

Plug in U1, PIC 18F1220 and apply power.

Expected result: red and green LEDs light for 2 seconds, then flash together quickly three times, followed by a gap, repeating indefinitely.

This suggests the software is running normally, and detecting the absence of a valid oscillator signal (as U3 is missing). This is Error Mode 1. See Section 7 for more on error modes.

Remove power.

**Test Passed**

### 4.2 Test 2 - Oscillator

Plug in U3, 74HC00 and re-apply power

Expected result: red and green LEDs light for 2 seconds, then flash alternately three times, followed by a gap, repeating indefinitely.

This suggests the software is detecting an in-range oscillator signal but is unable to control it (as U2 is missing). This is Error Mode 2. If Error Mode 1 persists, check the oscillator circuitry. See Section 7 for more on error modes.

Remove power.

**Test Passed**

### 4.3 Test 3 - DAC

Plug in U2, MCP4822 and re-apply power

Expected result: red and green LEDs light for 2 seconds, then red only lights for up to 30 seconds, then extinguishes. The green LED then flashes every 300ms or so, repeating indefinitely. This is the locked condition, indicating the control loop is established.

Remove power.

**Test Passed**

#### 4.4 Test 4 – Divider

Plug in the remaining IC, U4 74HC74. Re-apply power and wait a few seconds for the circuit to lock.

Apply 5V to PL1/6 TXA and confirm RF output on RFA1 and RFA2.

Similarly apply 5V to PL1/9 TXB and confirm RF output on RFB1 and RFB2.

The frequency should be around 3.620MHz in both cases.

Remove power

#### 4.5 Test 5 – Band switching

Connect PL2/2 BAND to 0V and re-apply power. The circuit will take up to 20 seconds or so to lock as the new empty channel places the processor into auto-setup (See Section 6.6).

Once locked, apply 5V to PL1/6 TXA and confirm RF output on RFA1 and RFA2.

Similarly apply 5V to PL1/9 TXB and confirm RF output on RFB1 and RFB2.

The frequency should be around 1.985MHz in both cases.

Remove power

#### 4.6 Test 6 - Frequency coverage

To check the frequency coverage without manually tuning from one end of the band to the other, Multi-Rock has a test mode. This is described in detail in Section 8 but for now simply follow the instructions below.

Before alignment can be carried out, the switches for tuning need to be connected. The channel switch can be ignored for this test. Decide what sort of switches are to be used, referring to the options detailed in Section 5, Interfacing.

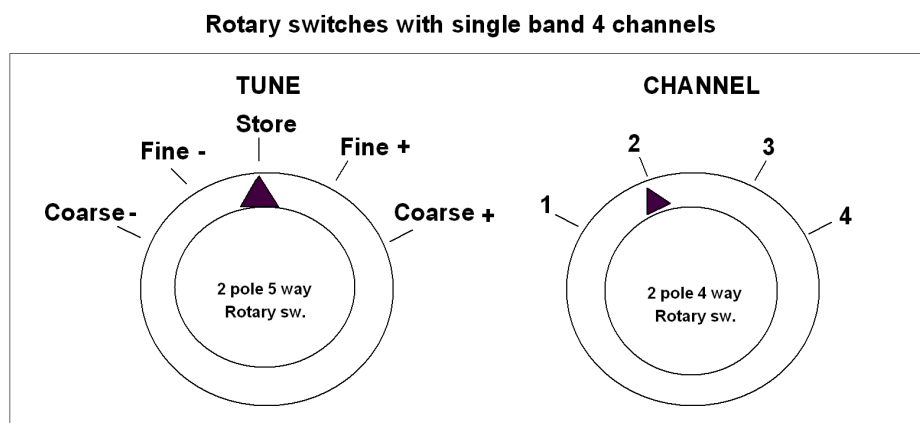

**Figure 4.1 Typical switch layout**

Figure 4.1 above shows a typical switch arrangement. Other options will be similar in functionality.

**Measuring the frequency**

Arrange to measure the frequency using either a sniffer wire near the circuit with a receiver connected, or a high impedance lead to a counter off the 2Fc line (at twice main output frequency) or one of the main output lines. (5V on TXA or TXB is required)

**Entering Test Mode**

Before applying power, set the tune switch to the 'coarse -' position (if toggle switches are used, set the coarse/fine switch to coarse and hold the centre biased up/down toggle on 'down')

Now apply power. Multi-Rock will enter Test Mode. (Toggle switch users may now release the up/down toggle switch). Multi-Rock will stay in test mode until power is re-applied with the tune switch set to 'store'.

**Minimum frequency**

Ensure the tune switch is still set to 'coarse -', or with toggle switches, select 'coarse' then press and hold the 'down' toggle. This sets the varicap voltage to zero, producing the lowest frequency. Note the frequency. Repeat this per band as required.

**Maximum frequency**

Set the tune switch to 'coarse +', or with toggle switches, select 'coarse' then press and hold the 'up' toggle. This sets the varicap voltage to maximum, producing the highest frequency. Note the frequency. Repeat this per band as required. The control range using the ceramic resonators supplied should be approximately 40kHz on 80m and approximately 15kHz on 160m.

**Frequency adjustment**

The frequency coverage has been reasonably consistent so far, although ceramic resonators can show some variation in frequency between samples. C5/C6 (80m) and C9/C10 (160m) can be changed to alter the frequency if required. Keep overall capacitance either side of the resonator similar for best pull-range bearing in mind the varicap capacitance as well. See Appendix 2 for ideas on how to increase frequency control range and add other bands.

Operation should be possible right up to the band edge as the fine-tune DAC is set to half scale during the band edge tests, still leaving scope for frequency stabilisation during normal operation. Note that the pull-range of the varicap will differ throughout the band as the varicap diodes are not perfectly linear, so the amount of correction the fine tune DAC can exert will also differ. Frequency swing in fact is greater per volt on the high side of the DAC voltage range. There should always be sufficient control range to keep the circuit locked even at the band edges but to make sure, try not to set channels closer than one or two kHz from a band edge.

Once the VCO coverage has been set, mount C5 (/C6) and C9/C10 correctly if they have been temporarily attached track-side.

**This completes formal testing of your Multi-Rock kit.**

**Now connect any hitherto unconnected channel switches and make sure all channel and band combinations work correctly.**

**For prospective FAT5 constructors, see Section 9 for a brief look at how simple it is to build a transmitter based around Multi-Rock as a signal source.**

**More FAT5 info at [www.s9plus.com](http://www.s9plus.com) 'projects'**

# 5. Interfacing

## 5.1 PCB Connectors

RF out and keying lines are controlled via 10-way connector PL1, while Tune and Channel control is via 10-way connector PL2. Power is supplied via a 4-way connector, PL3.

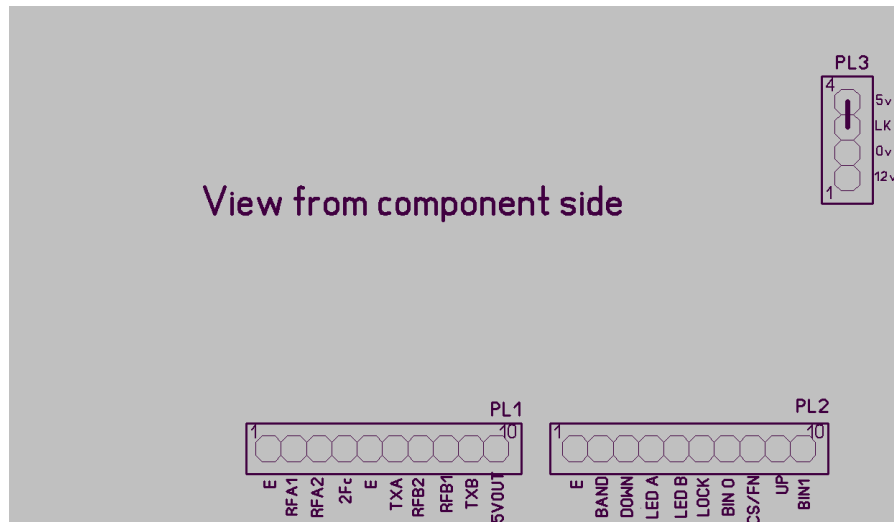

Figure 5.1 Location of connectors on PCB

<b>PL1/1</b>	0V (earth) Connects to ground plane of PCB
<b>PL1/2</b>	RFA 1. 0 degree TTL O/P gated by PL2/6 (TXA)
<b>PL1/3</b>	RFA 2. 180 degree TTL O/P gated by PL2/6 (TXA)
<b>PL1/4</b>	2Fc. Un-gated O/P at actual oscillator frequency
<b>PL1/5</b>	0V (earth) Connects to ground plane of PCB
<b>PL1/6</b>	TXA. Logic 1 enables RFA output.
<b>PL1/7</b>	RFB 2. 0 degree TTL O/P gated by PL2/9 (TXB)
<b>PL1/8</b>	RFB 1. 180 degree TTL O/P gated by PL2/9 (TXB)
<b>PL1/9</b>	TXB. Logic 1 enables RFB output.
<b>PL1/10</b>	5V. Connection to 5V regulated line. Use to enable TX A/B

<b>PL2/1</b>	0V (earth) Connects to ground plane of PCB
<b>PL2/2</b>	BAND. Unconnected (5V) = 80m, 0V = 160m
<b>PL2/3</b>	DOWN. Active low. Lowers frequency
<b>PL2/4</b>	LED A. Red. Un-Lock LED. Connect cathode to 0V
<b>PL2/5</b>	LED B. Green. Lock LED. Connect cathode to 0V
<b>PL2/6</b>	LOCK. Active high. Gate TXA/B when locked.
<b>PL2/7</b>	BIN 0. Binary 0 line for channel selection
<b>PL2/8</b>	Coarse / Fine. Tuning speed. n/c = coarse
<b>PL2/9</b>	UP. Active low. Raises frequency
<b>PL2/10</b>	BIN 1. Binary 1 line for channel selection

<b>PL3/1</b>	12V nominal power input to 7805 Regulator (min 7v, max 30)
<b>PL3/2</b>	0V (earth) Connects to ground plane of PCB
<b>PL3/3</b>	Link to PL1/4 ONLY when 7805 used
<b>PL3/4</b>	5V input

## 5.2 Switch Options

Switches are not supplied with the kit as they add considerably to the price and are not needed anyway for some configurations. Most shacks will have a junk-box containing suitable switches to get started.

There are two basic options – rotary switches or toggle switches (or a combination of both). The connection diagrams below show how to connect both types.

Other options are possible, such as replacing up/down toggles by push buttons.

### 5.2.1 Tuning Switch Options

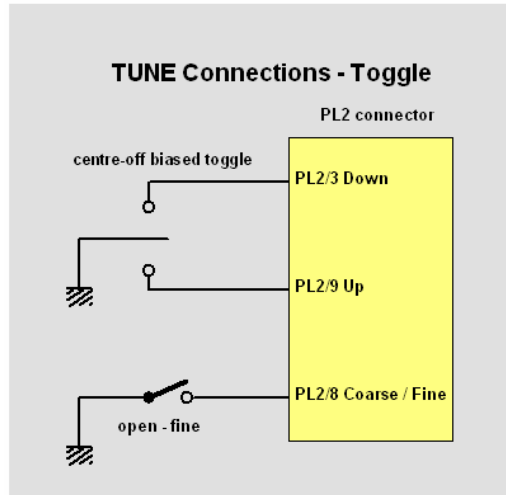
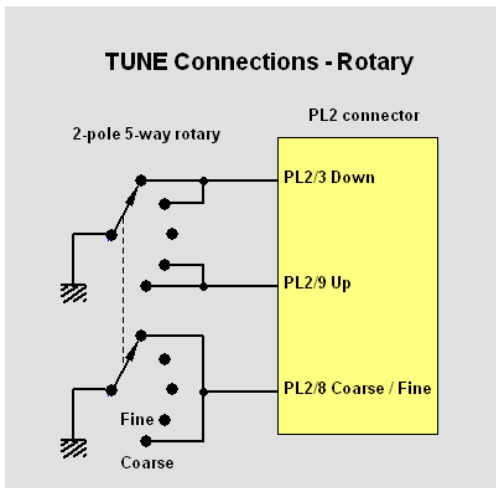

Rotary switch position 3 or the centre-off toggle position is the 'store' position. This is the default position for normal operation when not tuning.

### 5.2.2 Channel Switch Options

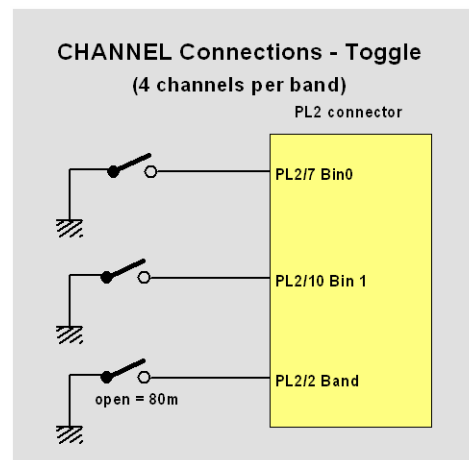
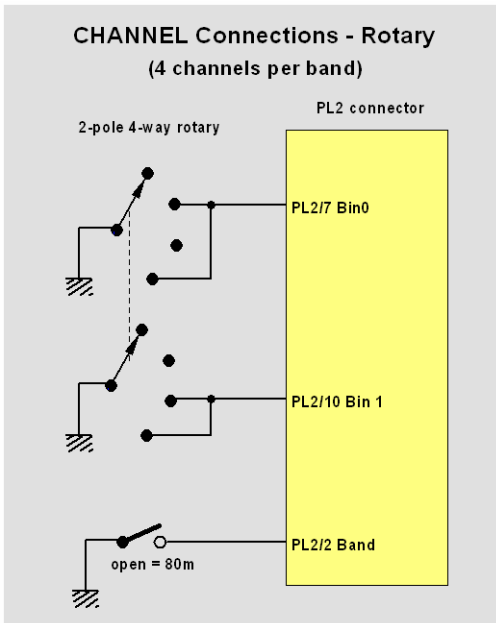

### 5.2.3 Switch layout examples

Example layouts for tuning and channel switching using rotary switches

Rotary switches with single band 4 channels

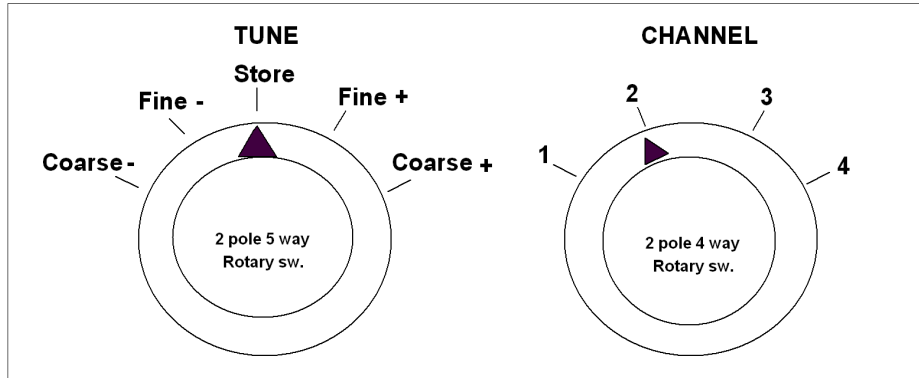

Rotary switches with dual band 2 channels per band

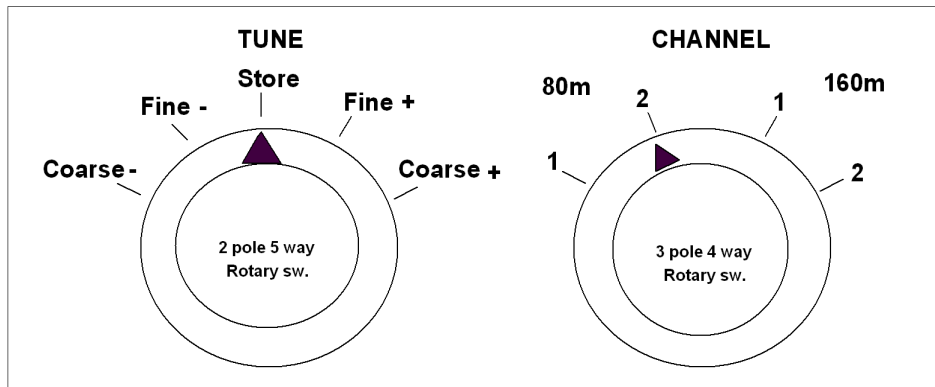

Rotary switches with dual band 4 channels

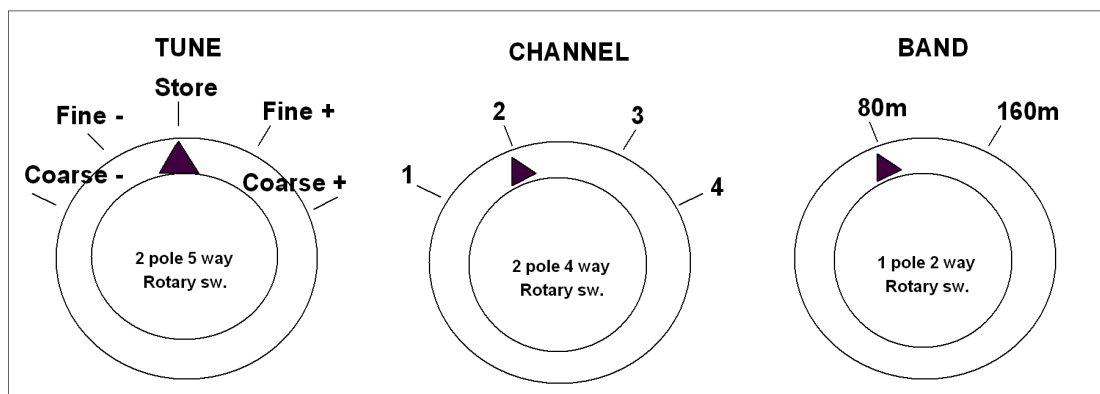

### 5.3 Single band operation

The band in use is selected by PL2/2, BAND. When unconnected, the PIC's internal pull-up resistor will produce 5V. This will enable the 80m oscillator. Ground PL2/2 for 160m.

Either RFA or RFB can be selected for the output signal depending on whether TXA or TXB is enabled (pin high). Enabling TXA and TXB together will produce output from both RFA and RFB.

The second output could be used to radiate a weak local signal for netting purposes, and a switch wired up rather like the Codar AT5 Net / TX switch.

The 2Fc (twice the carrier frequency) output is not gated and will always be present as one oscillator is always running. This line could be used for multiplication to other bands e.g. 10m (bear in mind higher bands will have greater frequency swing but less stability). The nominal X2 frequency of 7.37 MHz will produce a 10m carrier on 29.48MHz. Some experimentation with C5 and C6 may be necessary.

### 5.4 Dual band operation

Output on both bands can come from the same RF output lines (RFA or RFB) by using a single TXA or TXB line and band switching as normal via the band switch pin PL2/2. The unused output could then act as a net output similar to the suggestion for single band operation.

Alternatively, arranging band-sensitive switching for TXA and TXB will produce separate band outputs from RFA and RFB. This may be useful where separate single-band PAs are used. There is some merit to this approach rather than attempting to switch PA components, especially when differing band power levels are used e.g. 100W for 80m and say 10W for 160m.

### 5.5 Extended single band operation

For single band frequency coverage requirements where there is not enough frequency swing from the resonator, before using the LC alternative, consider using a similar resonator in the second VCO, but with different fixed value capacitors such that the two oscillators just overlap to provide a wider continuous coverage. In this configuration the band change input effectively becomes a third channel change line, and eight channels are available on the same band (still four per oscillator).

### 5.6 The LOCK line

The LOCK line (PL2/6) is high (5V) when the circuit is locked (i.e. the VCO is being controlled and stabilised by the PIC). This line is low on start-up until the circuit stabilises (normally less than 10 seconds). When changing channels, LOCK is also low until the new channel stabilises (normally less than 5 seconds, and often as little as 1 second, depending on how far the uncorrected VCO has drifted since that channel was last selected). If the LOCK line is used as a source of 5V for the TXA and TXB lines, transmit will be auto-inhibited when the circuit is unlocked. This is recommended for normal use although for testing purposes a hard 5V may be more useful.

### 5.7 The LEDs

Two high efficiency low-current red and green LEDs are provided with the kit. A single tri-state LED may be substituted. Bear in mind it needs to be common cathode.

Red LED A lights when the circuit is unlocked. It also lights when a high correction is being applied to the oscillator. This occurs momentarily on initial channel lock as the frequency 'zeroes-in' or when an unusually high level of drift is occurring (unlikely unless Multi-Rock is exposed to rapid temperature changes). At this time the Green LED B will also be flashing normally, and the LOCK line will be high as the frequency is considered close enough for normal use (i.e. as a signal source for AM operation). For testing, force this condition by touching the ceramic resonator in use with a finger, noting the LED behaviour.

### 5.8 Interfacing to valve equipment

This is not as daunting as may be thought. Multi-Rock can make a hybrid transmitter easily achievable. With the obvious caveat about high voltages, a circuit such as figure 5.2 below can be used. Multi-Rock was directly connected as shown. An input transformer or a pair of back-to-back 4.7V zeners in series across the input would offer useful protection should anything go wrong. This circuit was built and air tested by Steve GW1XVC. ■

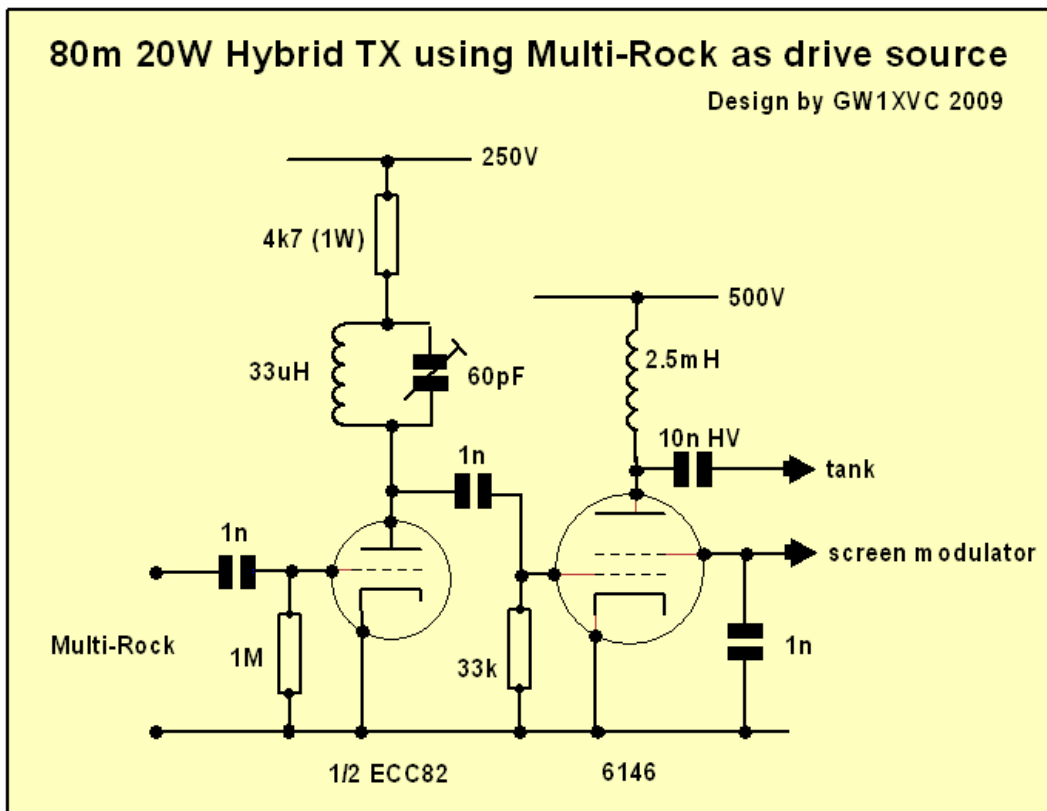
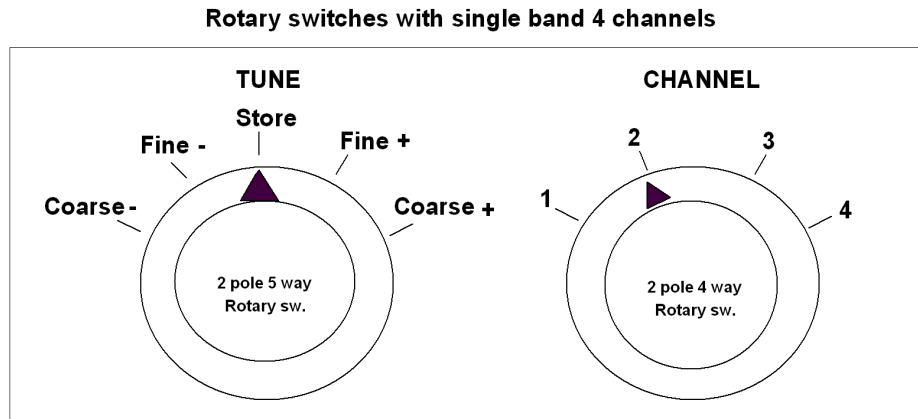

Figure 5.2 Example of simple valve transmitter (80m shown)

## 6. Operation



The description below relates to Figure 6.1 which shows a suggested switch layout using rotary switches. Alternative arrangements using toggle switches and push buttons will have the same functionality. The 'store' position for a biased toggle switch is the centre off position.

### 6.1 Power-up

For normal power-up make sure the tune switch is set to the centre 'store' position before applying power. If the tune switch is set to any other position Multi-Rock will power up in test mode. Refer to Section 8 for more information on test mode.

Multi-Rock will lock onto channel within 10 seconds from cold, or within 2 seconds if re-selecting a previously selected channel at the same temperature.

If the circuit is not operating normally an error condition may be indicated. Refer to Section 7 for more information on error mode.

### 6.2 Selecting a channel

Turn the channel select knob to the required channel. Multi-Rock will typically lock onto channel within 10 seconds from cold, or within 3 seconds if re-selecting a previously selected channel at the same temperature

### 6.3 Programming a channel

This is carried out using the tune control.

- Use the 'coarse +' and 'coarse -' positions to get as close as possible to the required frequency. Coarse tune has an auto-speedup function after one second.
- Then use 'fine +' and 'fine -' to trim out any remaining error. With a little practice it should be possible to set the VCO to within a few Hz of the desired frequency.
- Return the tune knob to the 'store' position. This will store the channel data into memory.

The tuning procedure may require passing through the centre 'store' position several times as the frequency is adjusted. This does not cause any problems. The tune rate will be much lower on 160m when using the resonator and coarse tuning only may be sufficient.

## 6.4 Adjusting a channel

If the user needs to fine-tune a channel during use, use the fine+ and fine- tune switch positions. Returning the tune switch to 'store' will update the memory with the new value.

## 6.5 LED interpretation

There are two LEDs, one green and one red. They could both be combined into a single dual LED if desired (common cathode type). Assuming separate LEDs are employed, the indications are as follows:

RED (LED A)	GREEN (LED B)	Indication	Lock O/P
Lit (2 sec)	Lit (2 sec)	Start-up	Low
Lit permanently	Unlit	Start-up in Test Mode or Coarse Net in progress	Low
Unlit	Flashes at approx 3Hz	Locked	High
Flashes at approx 3Hz	Flashes at approx 3Hz	Locked with large corrections	High
Flashes at approx 3Hz	Unlit	Attempting lock	Low

### During Tuning:

RED (LED A)	GREEN (LED B)	Indication	Lock O/P
Lit	Unlit	Coarse Tune	High
Unlit	Lit	Fine Tune	High
Lit for 0.5sec	Unlit	Storing new values	High

LED indications for error modes are covered in Section 7

## 6.6 Auto-Setup

When Multi-Rock is powered up on a channel for the first time ever, the memory channel will be empty. On discovering the empty channel, Multi-Rock performs an auto-setup. The DAC is set to half scale (approximately 2V) and the frequency this produces is counted. The count is then stored in the current memory along with the half scale DAC value. The control loop then maintains that frequency until it is re-tuned or the channel is changed.

In the event that the oscillator frequency range changes so much that a previously stored frequency / DAC value cannot be reproduced, then after a pre-set number of attempts to lock, the software 'gives up' and goes into auto-setup. This can happen for instance if the user decides to change the ceramic resonator or when using a coil that has been adjusted since the channel was last programmed. ■

## 7. Error Mode

On power-up, Multi-Rock checks there is a controllable frequency present. Two error conditions can be identified. These are indicated via the LEDs which flash in a unique way for each error.

### 7.1 Error Mode 1: No valid frequency present.

**Fail criteria:** 2Fc count less than 1MHz. No maximum count limit.

**Indication:** Both LEDs flash together quickly three times, followed by a gap, repeating indefinitely.  
(DAC output set at 0V for this test)

Suspect circuitry around U3, 74HC00. To force condition for testing, remove U3.

### 7.2 Error Mode 2: Frequency present but not controllable.

**Fail criteria:** Frequency window less than 10kHz. No maximum window value tested for.

**Indication:** The LEDs flash alternately three times, followed by a gap, repeating indefinitely.  
(DAC output set at 4V for this test)

Suspect circuitry around U2, DAC. To force condition for testing, remove U2.

Test 1 is carried out in first. Test 2 is not carried out unless Test 1 is passed.

### 7.3 Exiting Error Mode

If the fault is cleared the unit will start normally on next power-up, otherwise the state is permanent as long as the fault is present, as the code continuously repeats the checks.

To bypass Error Mode with a fault condition present, restart Multi-Rock in Test Mode (see Section 8). Test mode bypasses the error checks. ■

## 8. Test Mode

Test Mode provides a means of manually controlling the DAC voltage, which is very useful for establishing the required VCO coverage.

### 8.1 Entering Test Mode

Test Mode can only be entered at power-up. To initiate test mode earth either the 'up' or the 'down' pin during power-up. Multi-Rock responds by lighting the red LED, at which point the connection can be removed if desired. The red LED stays lit while in test mode.

### 8.2 Test Mode Checks

Test	Coarse / Fine setting	Up/Down setting	Oscillator output indicates:
1	Coarse	Down	Min VCO channel frequency
2	Coarse	Up	Max VCO channel frequency
3	Either	Both off	Centre frequency
4	Fine	Down	Stabilisation window (lower)
5	Fine	Up	Stabilisation window (upper)

The tests force the DAC to give various fixed-voltage outputs thus altering the VCO frequency.

#### Test 1 and test 2

With the *fine* DAC set to half scale (2V), the *coarse* DAC is set to zero and maximum (0V and 4V) to indicate the range of frequencies covered. This is the pull-range of the coarse DAC.

#### Test 3

Both DAC halves are set to half scale (2V). With perfectly linear varicap diodes (unlikely) this test would produce a frequency at the exact centre of the frequency window.

#### Tests 4 and 5

With the *coarse* DAC set to half scale (2V), the *fine* DAC is set to zero and maximum (0V and 4V) to indicate the channel stabilisation range at the centre frequency point. This is the pull range of the fine DAC.

### 8.3 Exiting Test Mode

Return the up/down inputs to the normal (open circuit) position then cycle the power. ■

## 9. FAT5

The FAT5 project is a solid state AM transmitter for 80m and 160m using a high efficiency Class E design for the PA. Multi-Rock directly interfaces to the PA driver ICs, as shown in figure 9.1 below.

Like any AM transmitter, FAT5 consists of three main parts, the RF section, Modulator and Power Supply.

### 9.1 FAT5 RF Section

The RF output from Multi-Rock is connected directly to the pair of inexpensive FET drivers such as the TC4422 from Microchip. These in turn directly connect to the main PA FETs. The PA is a push/pull configuration for greater power and lower harmonics. Single ended designs are also possible but require extra filtering. The PA tank is the only tuned circuit in the FAT5 design.

The FET drivers can drive several lower power FETs in parallel (e.g. IRF510). When higher powers are required, one driver per FET is needed. Construction is straight forward as the FET drivers and the PA FETs are bolted directly to the chassis or heatsink.

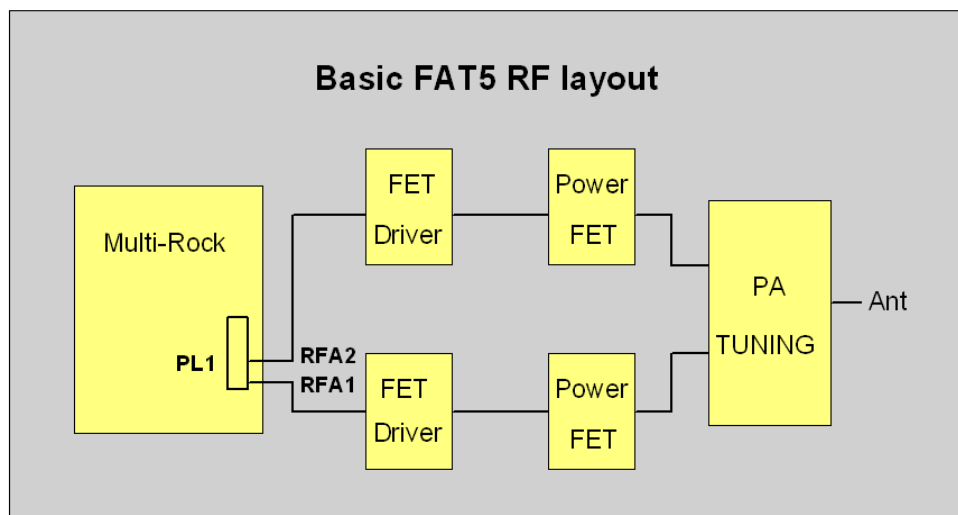

Figure 9.1 Diagram showing parts required for a simple class E transmitter

### 9.2 FAT5 Modulator

High level modulation via a modulation transformer or choke is possible however the design suits a straightforward series modulator, offering a low cost, low distortion alternative. The series modulator is capable of an extremely wide frequency response and an audio low-pass filter is required to define overall bandwidth. A class D pulse width modulator is also under consideration.

### 9.3 FAT5 Power Supply

The PSU requirements are straightforward, and a simple capacitor input PSU will suffice for lower power versions. Better performance and efficiency will be obtained with good quality switch mode PSUs which are obtainable at reasonable cost from eBay or Far East sources.

Please see [www.s9plus.com](http://www.s9plus.com) / projects for the latest FAT5 info.

# 10. Parts List

## 10.1 Component sourcing

The kit contains all components, sourced in quantity to reduce shipping costs and obtain quantity discounts where possible. This section may assist builders who prefer to source their own parts.

The design uses DIP packaged semiconductors for ease of construction. Components are currently available from various sources including the suppliers below.

Component	Farnell	RS Online
PIC18F1220 DIP	976-1977	467-1937
MCP4822 DIP	143-9413	681-1092
74HC00 DIP	160-7754	662-9988 (qty 5)
74HC74 DIP	147-0817	663-0433 (qty 5)
7.37 MHz resonator	160-5014	526-6104 (min qty 10)
4.00 MHz resonator	144-8125	196-839 (min qty 10)

Connector	Rapid
4 way straight socket	22-5104
4-way header plug	22-0505
10-way straight socket	22-5108
10-way header plug	22-0515

The resistors (1/2w 5%) are readily available at most component stockists as are the standard ceramic capacitors. C3 is a low voltage miniature radial electrolytic.

Connections to the board are via three SIL 2.54mm spacing connector blocks. PL1 and PL2 (RF and control) are 10-way connectors. PL3 (power input) is a similar 4-way connector.

Either headers or plugs can be PCB mounted. One option is to use a socket for one 10 pin connector and a header plug for the other 10 pin connector to avoid cable errors. Solder the chosen cable-side connector onto a strip of veroboard to act as solder pads for attaching cables.

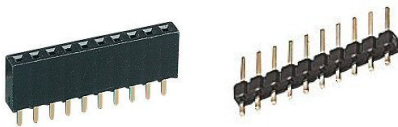

Connectors supplied

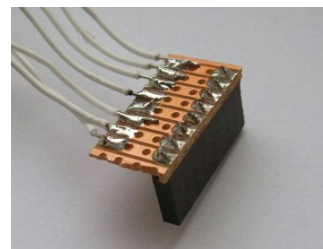

Use of Veroboard as solder tag-strip

## 10.2 PIC chip

The design uses a Microchip PIC 18F1220 microcontroller, which needs to be programmed with Multi-Rock firmware to function. 18F1230 PICs will also work as they are identical apart from having larger internal memory. The kit includes a pre-programmed 18F1220.

A free programming service is offered on receipt of a blank PIC and s.a.e. A .hex file is also available for constructors who are able to program their own PICs. The source code is not available. *Please contact gw4gte@s9plus.com for more details.*

## 10.3 Component list itemised by component reference

All resistors are 1/4w 5%. All capacitors are standard ceramic types apart from C3 (radial electrolytic).

Resistors	Value	Notes
R1	10k	Pull-up resistor
R2	10k	Pull-up resistor
R3	1k	LED current limiting
R4	1k	LED current limiting
R5	1k	Coarse tune ratio
R6	10k	Fine tune ratio
R7	47k	Coarse / Fine merge
R8	100R	X2 loading
R9	1M	Oscillator bias
R10	47k	VC1 isolation
R11	47k	VC2 isolation
R12	100R	X3 loading
R13	1M	Oscillator bias
R14	10k	Pull-down resistor
R15	10k	Pull-down resistor
R16	0R	Zero ohm link (single black band)
R17	0R	Zero ohm link
R18	0R	Zero ohm link
R19	0R	Zero ohm link
R20	0R	Zero ohm link

Capacitors		
C1	33pF	Oscillator X1 loading
C2	33pF	Oscillator X1 loading
C3	4u7	5V Decoupling <b>observe polarity</b>
C4	100n	5V Decoupling <b>(marked '104')</b>
C5	(68p)	Oscillator tuning – <b>sot (68p supplied)</b>
C6	(0p)	Oscillator tuning – <b>sot (C6 not supplied)</b>
C7	100n	DC isolation for VC1
C8	100n	Filtering for varicap tuning voltage
C9	(82p)	Oscillator tuning – <b>sot (82p supplied)</b>
C10	(47p)	Oscillator tuning – <b>sot (47p supplied)</b>
C11	100n	DC isolation for VC2
C12	100n	5V Decoupling
C13	100n	5V Decoupling <b>(use when U5 fitted, supplied)</b>
C14	100n	Unreg input Decoupling <b>(use when U5 fitted, supplied)</b>
C15	100n	5V Decoupling for U1 <b>(SMD, pre-fitted to PCB)</b>
C16	100n	5V Decoupling for U3
C17	100n	5V Decoupling for U4
C18	100n	5V Decoupling
C19	100n	5V Decoupling for U2

ICs		
U1	PIC 18F1220	Device needs programming – see 8.2 above
U2	MCP4822	2 channel 12bit DAC
U3	74HC00	Quad 2 input NAND
U4	74HC74	Dual D-type flip-flop
U5	7805	5V regulator (optional, supplied)
Misc		
X1	20MHz	Quartz (+/-20 ppm recommended)
X2	7.37MHz	Ceramic Resonator
X3	4.00MHz	Ceramic Resonator
VC1	ZC934	Varicap Diode (SMD pre-fitted to supplied PCB)
VC2	ZC934	Varicap Diode (SMD pre-fitted to supplied PCB)
IC skt	18 pin DIL	For U1
IC skt	8 pin DIL	For U2
IC skt	14 pin DIL	For U3
IC skt	14 pin DIL	For U4
10 pin header	Qty 2	PL1,PL2
4 pin header	Qty 1	PL3
10 pin socket	Qty 2	For PL1,PL2 connection
4 pin socket	Qty 1	For PL3 connection
PCB		Drilled, tinned PCB
LED	Red	
LED	Green	

#### 10.4 Resistors and Capacitors grouped by value

Value	Qty
<b>Resistors</b>	
0R	5
100R	2
1k	3
10k	5
47k	3
1M	2
<b>Capacitors</b>	
33p	2
47p	1
68p	1
82p	1
100n	12
4u7	1

# 11. Specification

**Frequency range:**

Frequency determined by tuned circuit components.  
Minimum frequency is set in software to 1MHz. Maximum > 10MHz

**Frequency stability of final output (locked):**

Stability of reference oscillator scaled to Fc, +/- 5Hz.

**Time to lock:**

**Power-up:** 10s or less

**Channel / Band change:** From cold .....10s or less  
Re-select .....1.5s to 5s

**Output:**

TTL level 5V p-p. Two pairs of anti-phase signals for push pull circuitry.  
Separate 2Fc permanently enabled output

**Supply voltage:**

5V regulated, or 8V to 30V unregulated via on-board regulator.

**Supply Current:**

50mA or less. ■



# Appendix 1: PCB layout

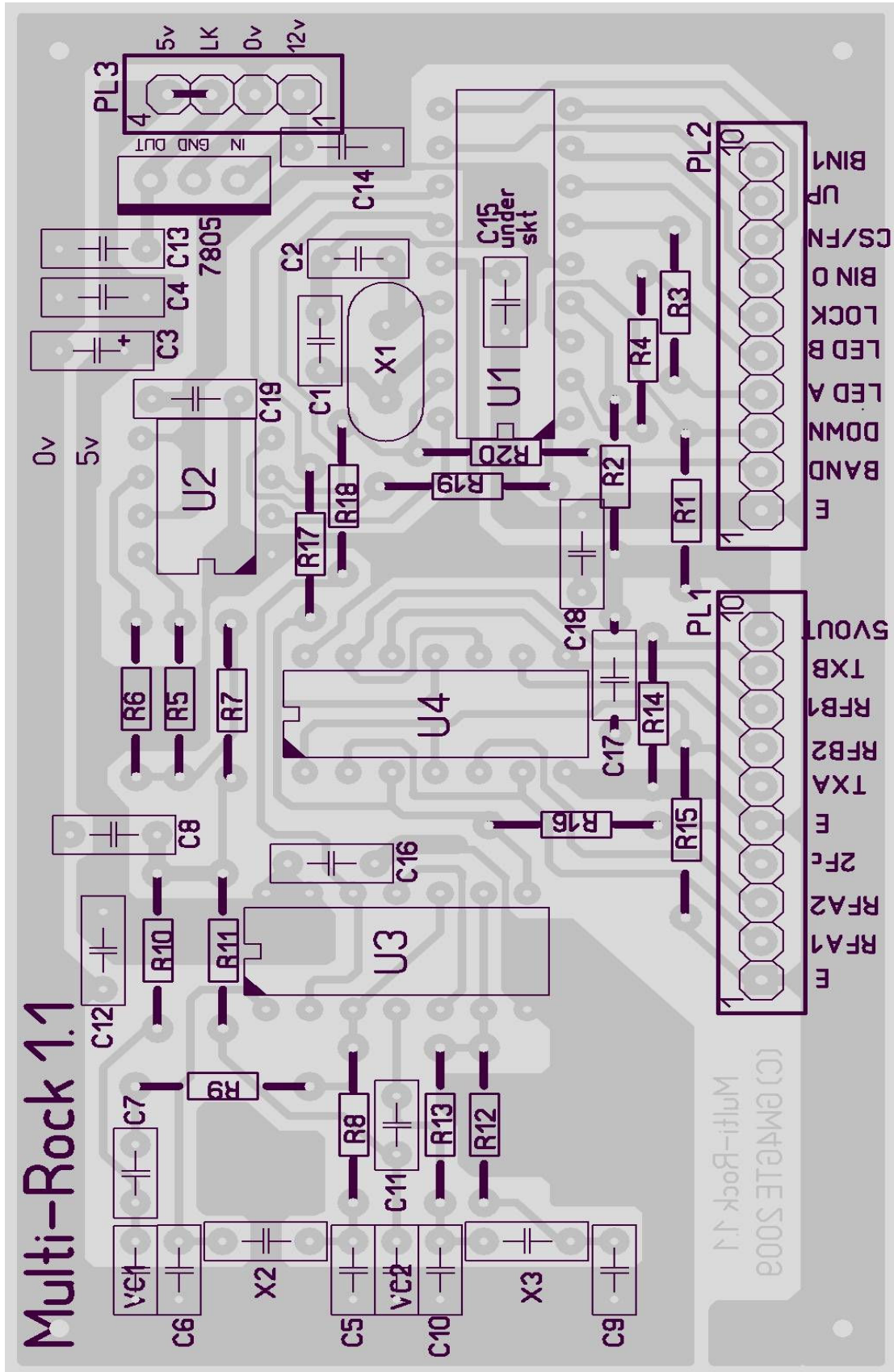

## Appendix 2: LC oscillator option

The use of a ceramic resonator for 80m is ideal for the UK AM part of 80m, but coverage is more limited on 160m due to the lower frequency resonator, and the reduced effect the varicap diode has at lower frequencies (More varicap diodes could be added in parallel for greater effect).

There is no reason why LC components cannot be substituted for the ceramic resonators as long as some slight circuit modifications are made. 160m coverage can be improved dramatically by using a circuit similar to the example below. The KANK3333 tuned readily to around 4MHz for 160m operation with the original ceramic resonator C values.

A DC isolation capacitor must be added (100n), and most importantly, the varicap isolation capacitor C11 now becomes a scaling capacitor and needs to be dramatically reduced in value.

### Modification for wide coverage on 160m

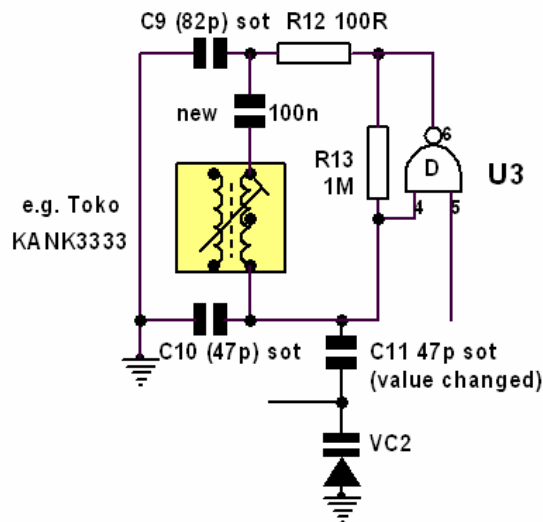

Figure A2.1 Example of LC oscillator

### A2.1 Determining C11 value

- Start Multi-Rock in Test Mode (See Section 8)
- Place the tuning control to the 'coarse -', then 'coarse +' positions. Measure the frequency at each position. The difference should ideally be no more than 100kHz. (Much more than this and the stabilisation system will tend to over-correct).
- Tune the coil to bring the oscillator into the right frequency range.
- Place the tuning control to the 'fine -', then 'fine +' positions. Measure the frequency at each position. The difference should be no more than 10kHz.
- Adjust C11 to produce the required frequency swing, re-adjusting the coil as required.

### A2.2 Using Multi-Rock at higher frequencies

LC oscillators using this technique have been tested up to 15MHz. As the frequency rises the VCO control becomes more sensitive, and the method of construction and mounting of the coil assumes greater importance. There is room for experimentation here.

Bronek, M0DAF has successfully modified both oscillators for LC operation in order to cover other sections of 80m, and plans to use the same technique for higher frequencies. Stagger tuning of the two oscillators effectively doubles the frequency swing on a single band.■

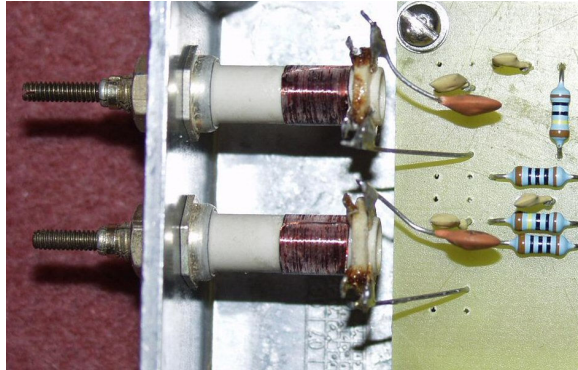

**Figure A2.2 Both oscillators modified for LC operation (M0DAF)**